

Description

- 0-10 metre sensing range
- 12 to 384 channels
- Channel spacing of 5, 10 or 20 mm
- Active length of 225 mm to 1920 mm
- Housing length of 300 mm to 1980 mm
- Plug connection
- 18-30 V dc supply voltage
- Power, output and system status indicators
- 33x36 mm aluminium housing with T-slot mounting
- High tolerance to hostile environments
- IO-Link communication interface
- Up to 4 digital outputs with software configurable functions
- Analogue output 4-20 mA and 0-10 V with software and control wire configurable function
- PC software for parameter configuration and diagnostics with optional USB-IO-Link Master 02

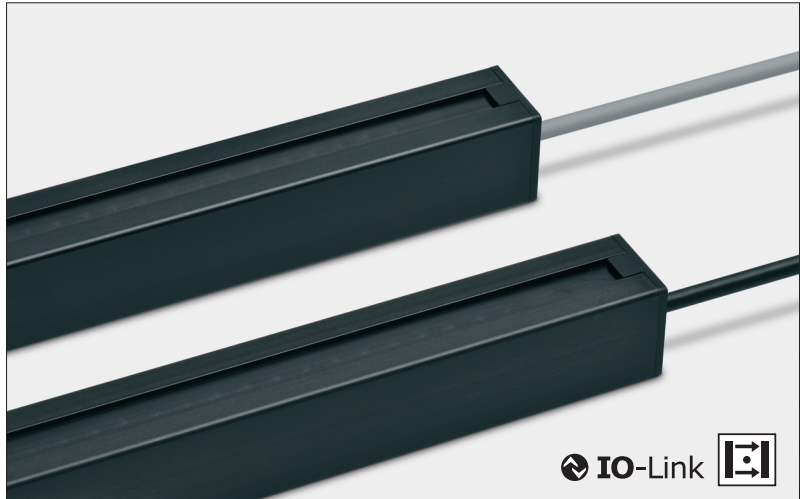

The SS 02-IO series is an advanced, industrial measuring light curtain system which consists of a self-contained transmitter SST and receiver SSR, which can either be positioned opposite or next to each other for thru beam or diffuse proximity mode. The light curtains are housed in sturdy aluminium profiles (33 x 36 mm) with T-slot mounting rail, available in lengths ranging from 300 mm to 1980 mm.

The SS 02-IO series supports a wide range of geometrical analysis functions which may be used for measurement, positioning and monitoring functions. This version of the SS 02 light curtain is equipped with an IO-link communication interface. Parameters and settings can be programmed and monitored through the IO-link interface. These selectable/adjustable settings include: scan mode, operation mode, gain

control/mode, hysteresis, blanking function and smoothing (pre-filtering) function. The light curtain offers a 2-wire analogue output (4-20 mA or 0-10 V) and up to four individual digital outputs which can be individually configured with a selection of a wide range of measurement and output conditions. A digital input is included to switch between two different output readings on the analogue output.

A test input in the SST may be used for either disabling or enabling the transmitting power temporarily for test purposes. The transmitter and receiver are electrically synchronised by wire connection. Both transmitter and receiver units are protected against reverse polarity of power supplies, control inputs and output signals. Output is protected against short circuit and inductive loads.

Technical Data						
		SST			SSR	
Supply voltage		18-30 V dc				
Current consumption		100 mA			75 mA	
Digital output	Type	-			NPN or PNP	
	Max. Load	-			100 mA	
Analogue output	Type	-			4-20 mA / 0-10 V (software selectable)	
	Current output load	-			≤ 600 Ohm	
	Voltage output load	-			≥ 1 kOhm	
	Bit resolution	-			16 bit	
IO-Link communication		-			Yes	
Light source		Infrared (880 nm)			-	
Channel spacing		5 mm	10 mm	20 mm	5 mm	10 mm 20 mm
Number of channels (diodes per detector)		48 ... 384	24 ... 192	12 ... 96	48 ... 384	24 ... 192 12 ... 96
Number of beams	Parallel	48 ... 384	24 ... 192	12 ... 96	48 ... 384	24 ... 192 12 ... 96
	Cross	142 ... 1150	70 ... 574	34 ... 286	142 ... 1150	70 ... 574 34 ... 286
Active length		225 ... 1920 mm				
Housing length		300 ... 1980 mm				
Max. response time		-			(N x 120 µs) + 2 ms	
Power on indicator		Green LED				
Output indicator		-			Yellow LED	
System status indicator		-			Red LED	
Housing dimensions (w x d)		33 x 36 mm				
Housing material	Profile	Aluminium (black anodised)				
	Lens cover	CoPET				
Connection Cable, PVC Ø 5,9 mm		0,5 m cable with 5 pin, M12 plug			0,5 m cable with 12 pin, M12 plug	

Note: "N" is equal to the number of beams (parallel or crossed).

Environmental Data

	SST	SSR
Vibration	10-55 Hz, 0,5 mm	
Shock	30 g	
Light immunity @ 5° incidence	-	100 000 lux
Temperature, operation	-30 to +60 °C	
Temperature, storage	-40 to +80 °C	
Sealing class	IP 67	
Approvals	CE UK CA	

Available Types

	Housing Length	Active Length	Number of Channels	Number of Beams Parallel / Cross	Channel Spacing	Connection	0.5 m cable with 5 pin, M12 plug	Range
						Output		
Transmitter	300 mm	240 mm	48	48 / 142	5 mm	-	SST 02-030-048-05-H-1D1-0.5-J5	10 m
	380 mm	320 mm	64	64 / 190			SST 02-038-064-05-H-1D1-0.5-J5	
	460 mm	400 mm	80	80 / 238			SST 02-046-080-05-H-1D1-0.5-J5	
	540 mm	480 mm	96	96 / 286			SST 02-054-096-05-H-1D1-0.5-J5	
	620 mm	560 mm	112	112 / 334			SST 02-062-112-05-H-1D1-0.5-J5	
	700 mm	640 mm	128	128 / 382			SST 02-070-128-05-H-1D1-0.5-J5	
	860 mm	800 mm	160	160 / 478			SST 02-086-160-05-H-1D1-0.5-J5	
	1020 mm	960 mm	192	192 / 574			SST 02-102-192-05-H-1D1-0.5-J5	
	1180 mm	1120 mm	224	224 / 670			SST 02-118-224-05-H-1D1-0.5-J5	
	1340 mm	1280 mm	256	256 / 766			SST 02-134-256-05-H-1D1-0.5-J5	
	1500 mm	1440 mm	288	288 / 862			SST 02-150-288-05-H-1D1-0.5-J5	
	1660 mm	1600 mm	320	320 / 958			SST 02-166-320-05-H-1D1-0.5-J5	
	1820 mm	1760 mm	352	352 / 1054			SST 02-182-352-05-H-1D1-0.5-J5	
	1980 mm	1920 mm	384	384 / 1150			SST 02-198-384-05-H-1D1-0.5-J5	
	300 mm	235 mm	24	24 / 70	10 mm	-	SST 02-030-024-10-H-1D1-0.5-J5	10 m
	380 mm	315 mm	32	32 / 94			SST 02-038-032-10-H-1D1-0.5-J5	
	460 mm	395 mm	40	40 / 118			SST 02-046-040-10-H-1D1-0.5-J5	
	540 mm	475 mm	48	48 / 142			SST 02-054-048-10-H-1D1-0.5-J5	
	620 mm	555 mm	56	56 / 166			SST 02-062-056-10-H-1D1-0.5-J5	
	700 mm	635 mm	64	64 / 190			SST 02-070-064-10-H-1D1-0.5-J5	
	860 mm	795 mm	80	80 / 238			SST 02-086-080-10-H-1D1-0.5-J5	
	1020 mm	955 mm	96	96 / 286			SST 02-102-096-10-H-1D1-0.5-J5	
	1180 mm	1115 mm	112	112 / 334			SST 02-118-112-10-H-1D1-0.5-J5	
	1340 mm	1275 mm	128	128 / 382			SST 02-134-128-10-H-1D1-0.5-J5	
	1500 mm	1435 mm	144	144 / 430			SST 02-150-144-10-H-1D1-0.5-J5	
	1660 mm	1595 mm	160	160 / 478			SST 02-166-160-10-H-1D1-0.5-J5	
	1820 mm	1755 mm	176	176 / 526			SST 02-182-176-10-H-1D1-0.5-J5	
	1980 mm	1915 mm	192	192 / 574			SST 02-198-192-10-H-1D1-0.5-J5	
	300 mm	225 mm	12	12 / 34	20 mm	-	SST 02-030-012-20-H-1D1-0.5-J5	10 m
	380 mm	305 mm	16	16 / 46			SST 02-038-016-20-H-1D1-0.5-J5	
	460 mm	385 mm	20	20 / 58			SST 02-046-020-20-H-1D1-0.5-J5	
	540 mm	465 mm	24	24 / 70			SST 02-054-024-20-H-1D1-0.5-J5	
	620 mm	545 mm	28	28 / 82			SST 02-062-028-20-H-1D1-0.5-J5	
	700 mm	625 mm	32	32 / 94			SST 02-070-032-20-H-1D1-0.5-J5	
	860 mm	785 mm	40	40 / 118			SST 02-086-040-20-H-1D1-0.5-J5	
	1020 mm	945 mm	48	48 / 142			SST 02-102-048-20-H-1D1-0.5-J5	
1180 mm	1105 mm	56	56 / 166	SST 02-118-056-20-H-1D1-0.5-J5				
1340 mm	1265 mm	64	64 / 190	SST 02-134-064-20-H-1D1-0.5-J5				
1500 mm	1425 mm	72	72 / 214	SST 02-150-072-20-H-1D1-0.5-J5				
1660 mm	1585 mm	80	80 / 238	SST 02-166-080-20-H-1D1-0.5-J5				
1820 mm	1745 mm	88	88 / 262	SST 02-182-088-20-H-1D1-0.5-J5				
1980 mm	1905 mm	96	96 / 286	SST 02-198-096-20-H-1D1-0.5-J5				

Note: 1. Special lengths are available upon request.

2. SS 02 series is available with  approved for Class II, Division 2, Groups F and G Hazardous Locations (E488233).

Add "UL-EX" after end of type name e.g. SST 02-030-048-05-H-1D1-0.5-J5 UL-EX.

Available Types								
	Housing Length	Active Length	Number of Channels	Number of Beams Parallel / Cross	Channel Spacing	Connection	Range	
						Output		0.5 m cable with 12 pin, M12 plug Order Reference
Receiver	300 mm	240 mm	48	48 / 142	5 mm	Refer to Available Output Configurations Table	SSR 02-030-048-05-H-IO-UUK-ZZW-0.5-J12	0-10 m
	380 mm	320 mm	64	64 / 190			SSR 02-038-064-05-H-IO-UUK-ZZW-0.5-J12	
	460 mm	400 mm	80	80 / 238			SSR 02-046-080-05-H-IO-UUK-ZZW-0.5-J12	
	540 mm	480 mm	96	96 / 286			SSR 02-054-096-05-H-IO-UUK-ZZW-0.5-J12	
	620 mm	560 mm	112	112 / 334			SSR 02-062-112-05-H-IO-UUK-ZZW-0.5-J12	
	700 mm	640 mm	128	128 / 382			SSR 02-070-128-05-H-IO-UUK-ZZW-0.5-J12	
	860 mm	800 mm	160	160 / 478			SSR 02-086-160-05-H-IO-UUK-ZZW-0.5-J12	
	1020 mm	960 mm	192	192 / 574			SSR 02-102-192-05-H-IO-UUK-ZZW-0.5-J12	
	1180 mm	1120 mm	224	224 / 670			SSR 02-118-224-05-H-IO-UUK-ZZW-0.5-J12	
	1340 mm	1280 mm	256	256 / 766			SSR 02-134-256-05-H-IO-UUK-ZZW-0.5-J12	
	1500 mm	1440 mm	288	288 / 862			SSR 02-150-288-05-H-IO-UUK-ZZW-0.5-J12	
	1660 mm	1600 mm	320	320 / 958			SSR 02-166-320-05-H-IO-UUK-ZZW-0.5-J12	
	1820 mm	1760 mm	352	352 / 1054			SSR 02-182-352-05-H-IO-UUK-ZZW-0.5-J12	
	1980 mm	1920 mm	384	384 / 1150			SSR 02-198-384-05-H-IO-UUK-ZZW-0.5-J12	
	300 mm	235 mm	24	24 / 70	10 mm	Refer to Available Output Configurations Table	SSR 02-030-024-10-H-IO-UUK-ZZW-0.5-J12	
	380 mm	315 mm	32	32 / 94			SSR 02-038-032-10-H-IO-UUK-ZZW-0.5-J12	
	460 mm	395 mm	40	40 / 118			SSR 02-046-040-10-H-IO-UUK-ZZW-0.5-J12	
	540 mm	475 mm	48	48 / 142			SSR 02-054-048-10-H-IO-UUK-ZZW-0.5-J12	
	620 mm	555 mm	56	56 / 166			SSR 02-062-056-10-H-IO-UUK-ZZW-0.5-J12	
	700 mm	635 mm	64	64 / 190			SSR 02-070-064-10-H-IO-UUK-ZZW-0.5-J12	
	860 mm	795 mm	80	80 / 238			SSR 02-086-080-10-H-IO-UUK-ZZW-0.5-J12	
	1020 mm	955 mm	96	96 / 286			SSR 02-102-096-10-H-IO-UUK-ZZW-0.5-J12	
	1180 mm	1115 mm	112	112 / 334			SSR 02-118-112-10-H-IO-UUK-ZZW-0.5-J12	
	1340 mm	1275 mm	128	128 / 382			SSR 02-134-128-10-H-IO-UUK-ZZW-0.5-J12	
	1500 mm	1435 mm	144	144 / 430			SSR 02-150-144-10-H-IO-UUK-ZZW-0.5-J12	
	1660 mm	1595 mm	160	160 / 478			SSR 02-166-160-10-H-IO-UUK-ZZW-0.5-J12	
	1820 mm	1755 mm	176	176 / 526			SSR 02-182-176-10-H-IO-UUK-ZZW-0.5-J12	
	1980 mm	1915 mm	192	192 / 574			SSR 02-198-192-10-H-IO-UUK-ZZW-0.5-J12	
	300 mm	225 mm	12	12 / 34	20 mm	Refer to Available Output Configurations Table	SSR 02-030-012-20-H-IO-UUK-ZZW-0.5-J12	
	380 mm	305 mm	16	16 / 46			SSR 02-038-016-20-H-IO-UUK-ZZW-0.5-J12	
	460 mm	385 mm	20	20 / 58			SSR 02-046-020-20-H-IO-UUK-ZZW-0.5-J12	
	540 mm	465 mm	24	24 / 70			SSR 02-054-024-20-H-IO-UUK-ZZW-0.5-J12	
	620 mm	545 mm	28	28 / 82			SSR 02-062-028-20-H-IO-UUK-ZZW-0.5-J12	
	700 mm	625 mm	32	32 / 94			SSR 02-070-032-20-H-IO-UUK-ZZW-0.5-J12	
	860 mm	785 mm	40	40 / 118			SSR 02-086-040-20-H-IO-UUK-ZZW-0.5-J12	
	1020 mm	945 mm	48	48 / 142			SSR 02-102-048-20-H-IO-UUK-ZZW-0.5-J12	
1180 mm	1105 mm	56	56 / 166	SSR 02-118-056-20-H-IO-UUK-ZZW-0.5-J12				
1340 mm	1265 mm	64	64 / 190	SSR 02-134-064-20-H-IO-UUK-ZZW-0.5-J12				
1500 mm	1425 mm	72	72 / 214	SSR 02-150-072-20-H-IO-UUK-ZZW-0.5-J12				
1660 mm	1585 mm	80	80 / 238	SSR 02-166-080-20-H-IO-UUK-ZZW-0.5-J12				
1820 mm	1745 mm	88	88 / 262	SSR 02-182-088-20-H-IO-UUK-ZZW-0.5-J12				
1980 mm	1905 mm	96	96 / 286	SSR 02-198-096-20-H-IO-UUK-ZZW-0.5-J12				

- Note: 1. Special lengths are available upon request.
 2. SS 02 series is available with  approved for Class II, Division 2, Groups F and G Hazardous Locations (E488233).
 Add "UL-EX" after end of type name e.g. SSR 02-030-048-05-H-IO-UUK-ZZW-0.5-J12 UL-EX.

Available Output Configurations			
Type Number Designation in SSR 'IO-UUK-ZZW'	Analogue Output	Digital Outputs	IO-Link
IO-AC2-DN2	4-20 mA / 0-10 V (2-wire)	2 x NPN	Yes
IO-AC2-DP2	4-20 mA / 0-10 V (2-wire)	2 x PNP	Yes
IO-ANN-DN4	None	4 x NPN	Yes
IO-ANN-DP4	None	4 x PNP	Yes

Note: Different output configurations are available upon request.

Connections

	M12 Plug / Cable	
	SST	SSR
Supply +	Pin 1 / Brown	Pin 1 / Brown
Supply -	Pin 3 / Blue	Pin 2 / Blue
Common sync +	Pin 2 / White	Pin 3 / White
Common sync -	Pin 5 / Grey	Pin 4 / Grey
Test input	Pin 4 / Black	-
Digital input 1	-	Pin 6 / Yellow
IO-Link	-	Pin 11 / Grey-Pink
Not used	-	Pin 12 / Red-Blue
Digital output 1	-	Pin 10 / Violet
Digital output 2	-	Pin 5 / Pink
Digital output 3 / Analogue out -	-	Pin 8 / Green
Digital output 4	-	Pin 9 / Red
Analogue out +	-	Pin 7 / Black

5 pin, M12

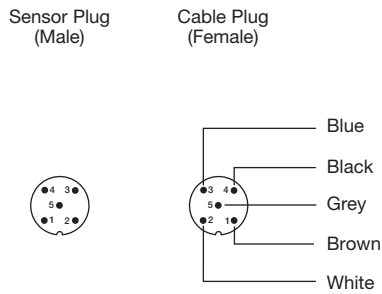

12 pin, M12

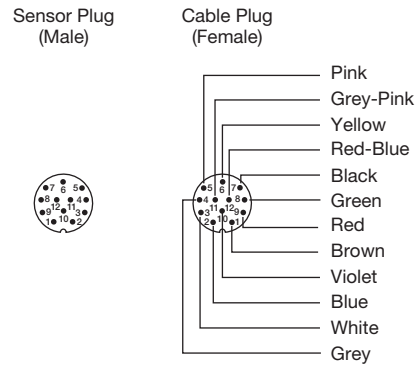

Wiring Diagrams

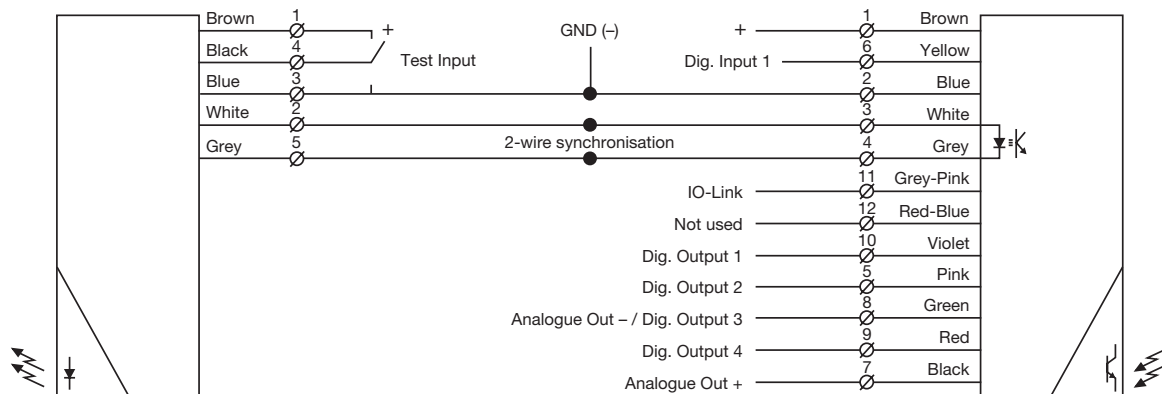

SST 02
Connect black test input wire to + or - to disable SST

SSR 02-10

Dimensions and Descriptions

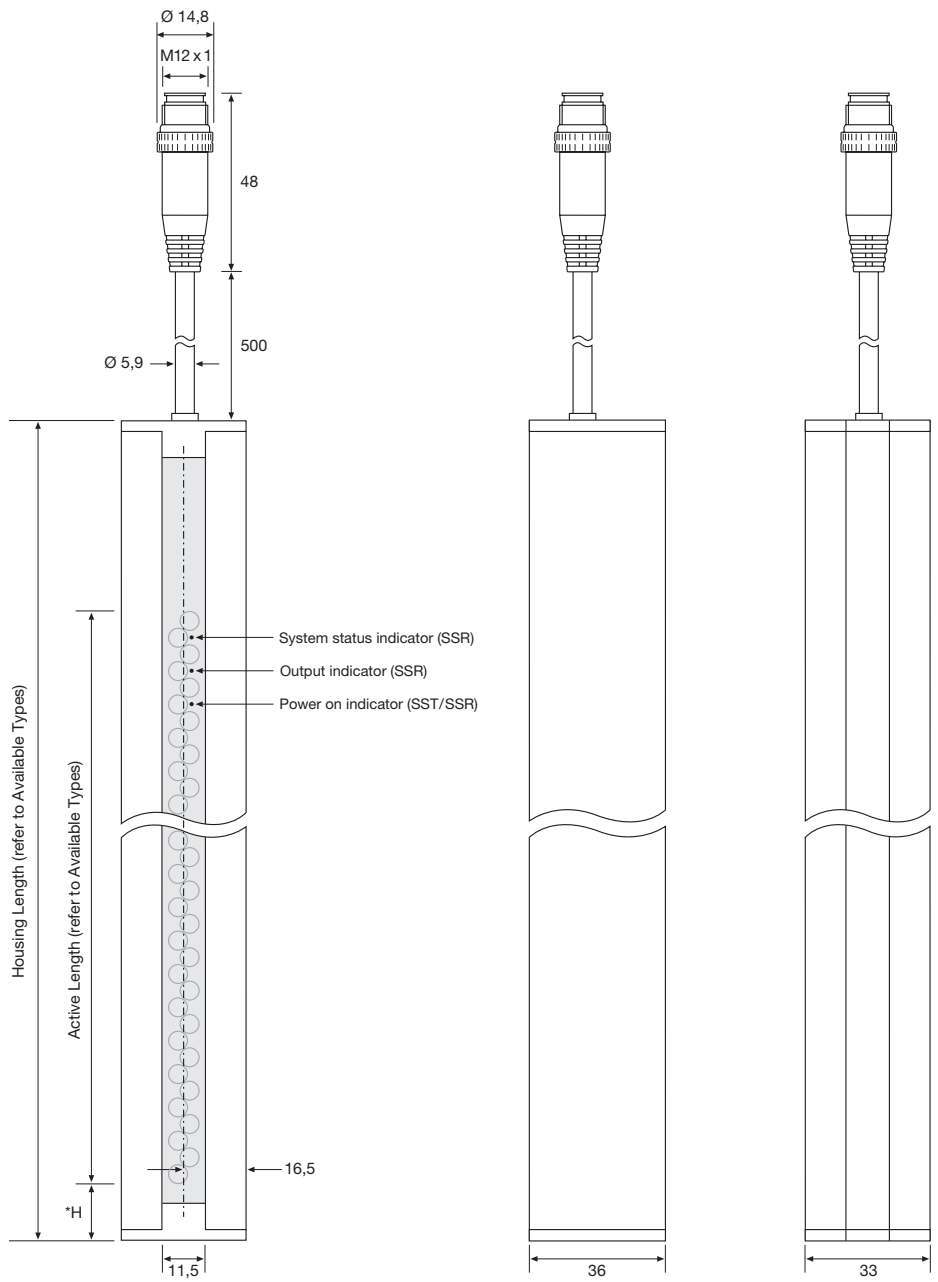

*H =
 5 mm channel spacing: 13,8 mm
 10/20 mm channel spacing: 15,8 mm

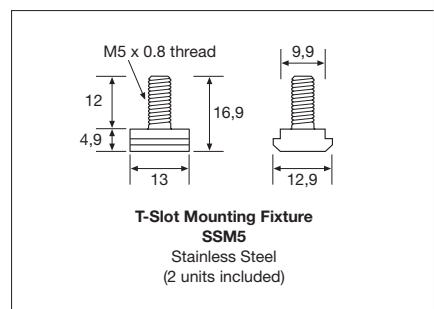
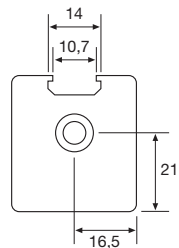

(Units in mm)

Beam Patterns

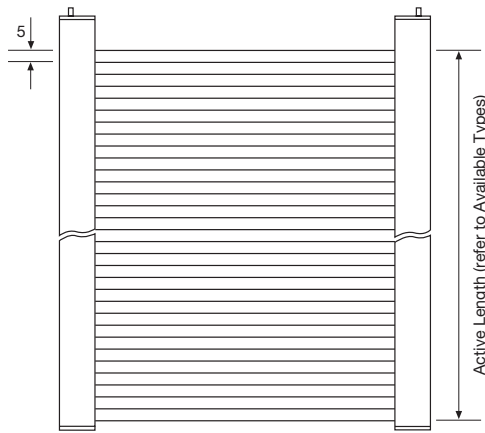

Parallel Beams

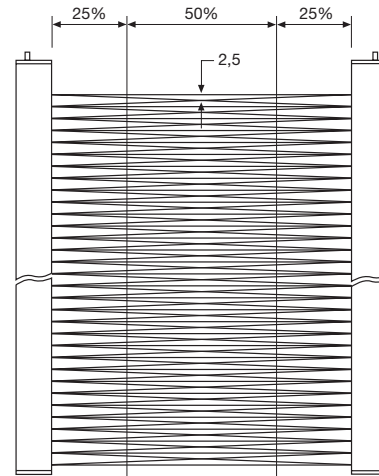

Cross Beams

5 mm channel spacing

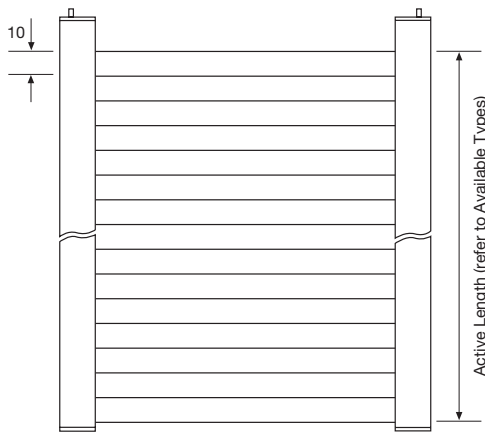

Parallel Beams

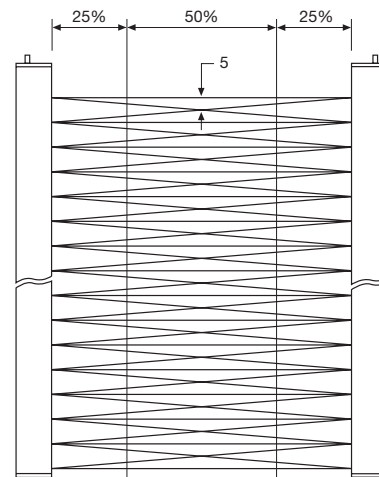

Cross Beams

10 mm channel spacing

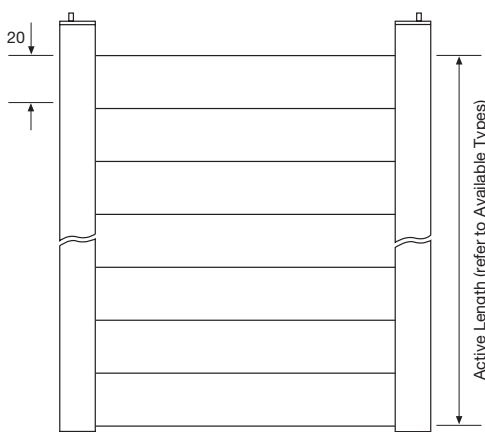

Parallel Beams

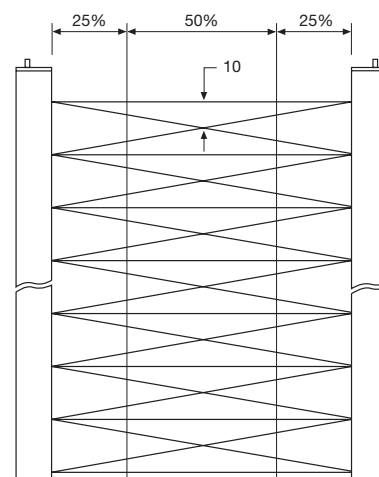

Cross Beams

20 mm channel spacing

(Units in mm)

Sensing Characteristics

Parallel Displacement

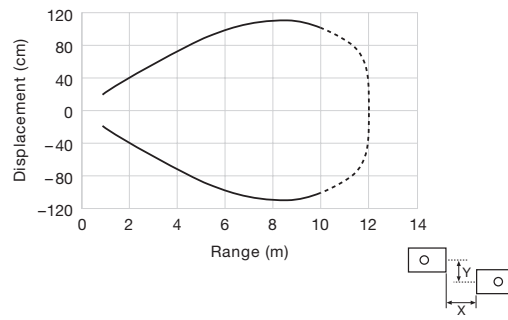

Mounting Bracket

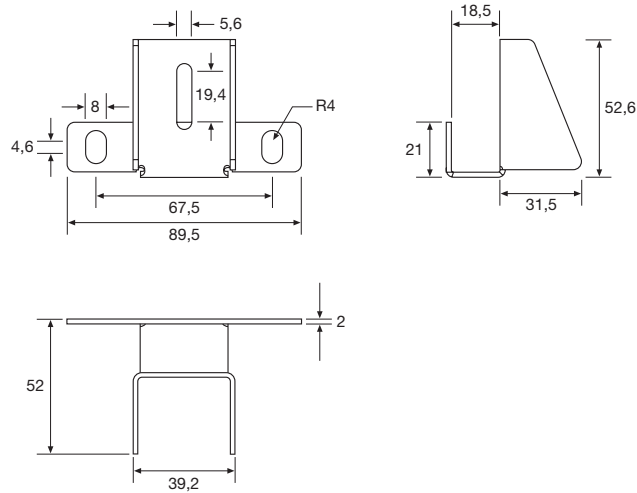

TR SS53 USA
Stainless Steel AISI 316
(to be ordered separately)

(Units in mm)

SpaceScan PC Programming and Monitoring

General Setup

	Name	Description	Value Range
1	Scan Mode	Select scan mode	Parallel beam scanning / Crossed beam scanning
2	Gain Control	Select gain control mode	Manual gain / Automatic gain
3	Automatic Excess Gain Level	Set the excess gain level of receiver, when used in automatic gain mode	0-255 (2 - 10)
4	Manual Gain Level	Adjust the gain level of the receiver	0-255 (0 - 100%)
5	Hysteresis Level	Adjust the hysteresis level	0-255 (0% - 35%)
6	Digital Output INV	Invert the status of all digital outputs	True / False
7	Hole Detection	Invert the status of all beams	Selected / Not selected
8	Minimum Size of Coherent Area	Specifies the maximum size of objects that shall be ignored	Beam number
9	Don't Save Settings	Settings will not be saved in permanent memory	True / False

USB-IO Link Master 02 PC Software Screenshot

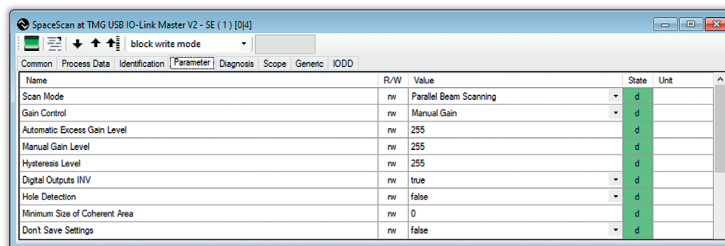

SpaceScan PC Programming and Monitoring

Analogue Output

	Name	Description	Value Range
1	Enabled	Output is enabled or disabled	True / False
2	Type	Select between 4-10 mA current or 0-10 V voltage output	Current / Voltage
3	Function (Control Input High)	Select the function that becomes active when control input is high	DIS, FBB, .. SD
4	Function (Control Input Low or Not Connected)	Select the function that becomes active when control input is low	DIS, FBB, .. SD
		Output is disabled, i.e. constantly de-energised	DIS: Disabled Output
		Position of the first beam blocked	FBB: First Beam Blocked
		Position of the first beam made	FBM: First Beam Made
		Position of the last beam blocked	LBB: Last Beam Blocked
		Position of the last beam made	LBM: Last Beam Made
		Position of the (FBB+LBB) / 2 rounded to nearest integer	MBB: Middle Beam Blocked
		Total number of beams blocked	TBB: Total Beams Blocked
		Total number of beams made	TBM: Total Beams Made
		Reads out the number of beams in the largest group of adjacent beams blocked	CBB: Contiguous Beams Blocked
		Reads out the number of beams in the largest group of adjacent beams made	CBM: Contiguous Beams Made
		The number of transitions in the beam pattern between made beams and blocked beams	TRN: Number of Transitions
		Reads out LBB - FBB+1, corresponding to the size of a single object contained in the beam pattern, counted in beam breaks	OD: Outside Dimensions
		Reads out the count of beams made between first beam broken and last beam broken. This corresponds to the size of a hole in a single solid object in the light curtain	ID: Inside Dimensions
5	Minimum Speed Control High	The velocity that corresponds to 4 mA / 0 V. When AO is in Speed and Direction mode and Control input is High	-4000 - 4000 (-40.00 - 40.00 m/s)
6	Maximum Speed Control High	The velocity that corresponds to 20 mA / 10 V. When AO is in Speed and Direction mode and Control input is High	-4000 - 4000 (-40.00 - 40.00 m/s)
7	Minimum Speed Control Low	The velocity that corresponds to 4 mA / 0 V. When AO is in Speed and Direction mode and Control input is Low or NC	-4000 - 4000 (-40.00 - 40.00 m/s)
8	Maximum Speed Control Low	The velocity that corresponds to 20 mA / 10 V. When AO is in Speed and Direction mode and Control input is Low or NC	-4000 - 4000 (-40.00 - 40.00 m/s)
9	Force Set Enable	Allows the user to write values direct to the analogue output	True / False
10	Forced Value	Defines the value of the analogue output (in beam position)	0 - 384 beams
11	Moving Average Time Constant	The analogue output is filtered with a moving average	0 to 2000 ms

USB-IO Link Master 02 PC Software Screenshot

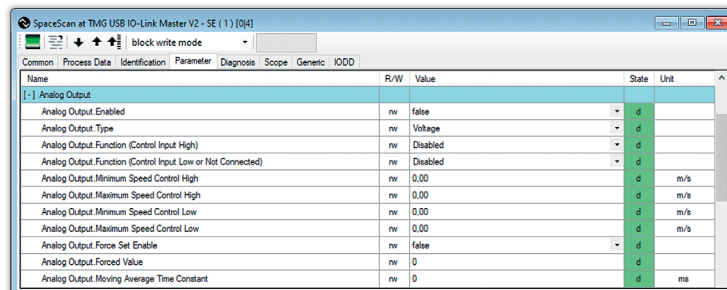

SpaceScan PC Programming and Monitoring

SIO / Digital Output

	Name	Description	Value Range
1	Enabled	Output is enabled or disabled	True / False
2	Function	Select output function used for comparison	DIS, FBB, .. SA
		Output is disabled i.e. constantly de-energised	DIS: Disabled Output
		Position of the first beam blocked	FBB: First Beam Blocked
		Position of the first beam made	FBM: First Beam Made
		Position of the last beam blocked	LBB: Last Beam Blocked
		Position of the last beam made	LBM: Last Beam Made
		Position of the (FBB+LBB) / 2 rounded to nearest integer	MBB: Middle Beam Blocked
		Total number of beams blocked	TBB: Total Beams Blocked
		Total number of beams made	TBM: Total Beams Made
		Reads out the number of beams in the largest group of adjacent beams blocked	CBB: Contiguous Beams Blocked
		Reads out the number of beams in the largest group of adjacent beams made	CBM: Contiguous Beams Made
		The number of transitions in the beam pattern between made beams and blocked beams	TRN: Number of Transitions
		Reads out LBB - FBB+1, corresponding to the size of a single object contained in the beam pattern, counted in beam breaks	OD: Outside Dimensions
		Reads out the count of beams made between first beam broken and last beam broken. This corresponds to the size of a hole in a single solid object in the light curtain	ID: Inside Dimensions
3	Operator	Select comparison operator	<, >, □, □, =
4	Function Compare Value	Select value to compare with	0 - 1000
5	ABBA: Level 1	Output changes status if any beam is blocked within the area(s) set in the Low / High limit	0 - 384 Beam
6	ABBA: Level 2	Output changes status if any beam is blocked within the area(s) set in the Low / High limit	0 - 384 Beam
7	Force Set Enable	Allows the user to set the value of the digital output	True / False
8	Forced On	Output is set to high or low	True / False
10	On-Delay	On-delay time between the expression becomes true and the output is switched	0 - 400 (0.0 - 10.0 s)
11	Off-Delay	Off-delay time between the expression becomes false and the output is switched	0 - 400 (0.0 - 10.0 s)

USB-IO Link Master 02 PC Software Screenshot

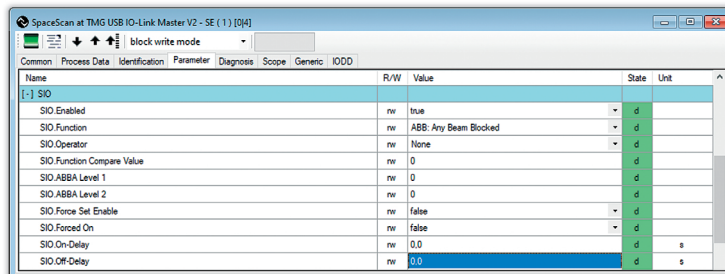

SpaceScan PC Programming and Monitoring

Blanking

	Name	Description	Value Range
1	Measure Blanking From Light Curtain	Obstructed areas are read from light curtain and written as text in blanking text box. Blanked beams can be seen in values for Write Blanking to Light Curtain after upload	True (write only)
2	Blanking [1]	Blanking value for first set of 8 beams in a binary value	0 - 255 (0-8 beams blanked)
3	Blanking [2]	Blanking value for second set of 8 beams in a binary value	0 - 255 (0-8 beams blanked)
4	Blanking [3]	Blanking value for third set of 8 beams in a binary value	0 - 255 (0-8 beams blanked)
..			
49	Blanking [48]	Blanking value for beam 377 to 384	0 - 255 (0-8 beams blanked)

USB-IO Link Master 02 PC Software Screenshot

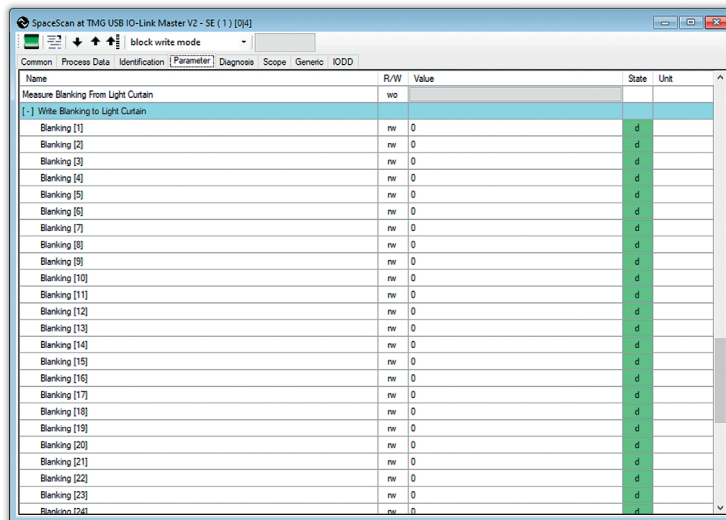

SpaceScan PC Programming and Monitoring

Process Data

	Name	Description	Value Range
1	SIO	Indicates status of SIO output	True / False
2	Digital Output 1	Indicates status of digital output 1	True / False
2	Digital Output 2	Indicates status of digital output 2	True / False
3	Digital Output 3	Indicates status of digital output 3	True / False
4	Digital Output 4	Indicates status of digital output 4	True / False
5	Digital Input 1	Indicates status of digital input 1	True / False
6	Analogue Output Value	Indication of the analogue output value	0 - 384 Beams
7	Signal Alarm	Indicates a pre-warning of low signal level	True / False

USB-IO Link Master 02 PC Software Screenshot

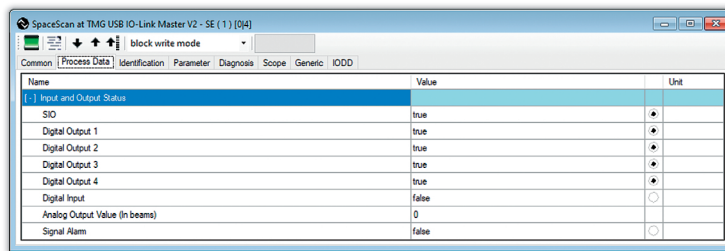

Telco reserves the right to change specifications without notice.